

Gate Valve Manual

1. Function, Performance and Characteristic

By the movement of stem, the wedge is forced to Open/Close.

The advantage of gate valve is less obstruction, easy open/close, short face-to-face dimension and unlimited to the direction of medium. The disadvantages are complex double sealing surface processing, high cost, large volume, long opening or closing time, and easy friction.

2. Main Structure and Operation

2.1 Main Structure

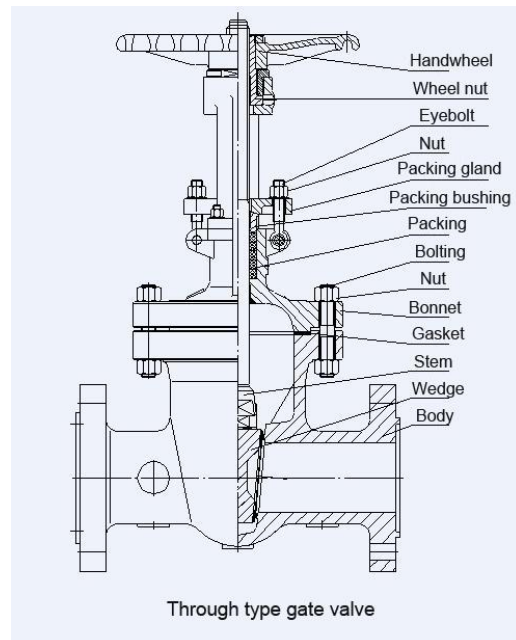
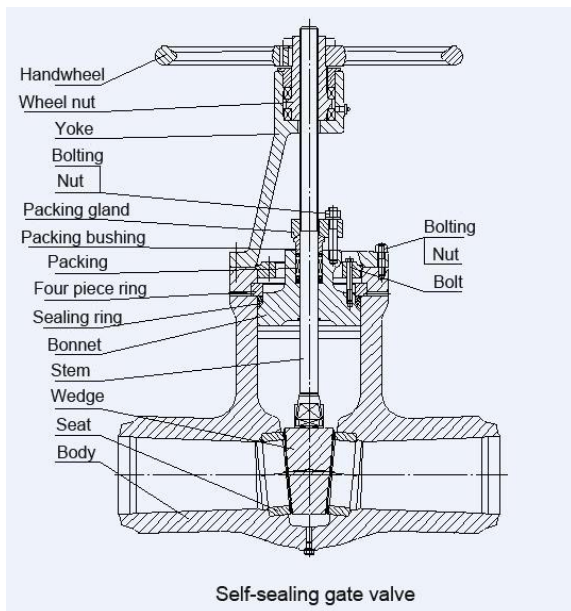

2.2 Movement and Working

Hand-wheel brings the movement of wheel-nut, which drives the movement of stem. The stem is connected with the wedge by a T type groove. There are movement-leading grooves by



both side of body to ensure vertical movement of the wedge. Overlay welding is used between the valve body and the wedge to ensure the sealing of the wedge.

In order to ensure sealing capacity, stuffing box is filled with graphite. At the same time, concerning to packing-replacement and prevent medium flushing on working conditions, a back seal structure is designed in order to ensure the sealing of valve open/close.

3. Structure Characteristic

3.1 Less fluid resistance----- The internal structure of gate valve is the through type, medium will not change flow direction when passing by.

3.2 Small torque when open/close----- Flow direction of the medium is vertical to wedge, therefore, the torque is smaller comparing to globe valve.

3.3 Medium direction is not confined----- Medium is able to go through from both direction of a gate valve, which enables it for the application of direction-changing medium.

3.4 Short face-to-face dimension----- The wedge is vertical to flow direction, therefore, the dimension is shorter than horizontal sealing valves, such as globe valve.

3.5 Good sealing capacity----- Less erosion force when fully opened. The wedge type structure enables good sealing capacity of valve.

3.6 Easy damage of sealing face----- There are frictions between wedge and seat when open/close.

3.7 Long period Open/Close, larger size.

3.8 Complex structure and multiple components.

4. Main Dimension and Connection Size

5. Packing and Delivery

5.1 Preparation before Delivery

Medium touching pars and stem are the key parts of a valve, following measures are adopted:



- (a) The inside of the valve should be kept clear, clean and dry.
- (b) The outer machine part of a valve shall be de-rust and protected by pickling oil.
- (c) The end part of the valve shall be prevention strategies to prevent mechanical damage.
- (d) Valve closure parts shall be in the state of Closing.

5.2 Lifting

Be cautious when lifting. Throwing or falling down is utterly forbidden, especially hand-wheel and stem shall not be the lifting point.

5.3 Stocking

Pay attention that the problem of storage and transport preparation are usually the same. Time is very important, Generally the storage period of check valve is according to the shelf-life of seal ring material. If want to extend the storage of the valve for a few weeks or months, it needs to improve the conditions of the original storage. Generally, the actual temperature of valves stored indoors is always higher than the dew point temperature. If the valve must be stored outdoors, it should be supported, not allowed to touch the ground, and protected with a waterproof cover.

6. Installation

6.1 Installation is the key to determining the service life. Improper installation is likely to cause performance degradation. Therefore, the following items should be confirmed before installing the valve:

- (a) Carefully unpack the cases. Read the material, specification, tags and so on to make sure the valve is qualified to install.
- (b) Do pay attention to the warnings on a valve tag, and following instructions.
- (c) Check the flow direction mark. If the valve is marked with flow direction, valve must be installed as per this direction.
- (d) Check and find if the valve tunnel is clean, safe and without any corrosive substances.



Get rid of packing and stuffings which blocks movement of a valve.

- (e) Check if pipings to connect valve are clean. If not, clean before installation.

6.2 Flanged Valve Installation

The capacity of piping flanges and valve depends the deformation of gaskets. The mechanical force generated by the bolt connection must not only resist the normal pressure on the joint that makes the connection loose, but also maintain the necessary gasket compression stress on the gasket. Take note that the force does not exceed the gasket load and pressure load. In order to ensure good connection, following instructions shall be noted:

- (a) Check flange surface. If any defect appears leakage, groove or impress, repair before installation.

- (b) Check dimension, length and material to make sure they are fit for installation. Low-temperature valves must be installed with the bolts that are made of low-temperature material.

- (c) Check gasket material. Gasket to connect valve and piping shall have reliable sealing capacity and recovery among regular temperature, low temperature and temperature changing.

- (d) Gaskets have the capacity of resisting deformation and damage.

- (e) Check the centration of assemble-part flanges. Lubricate the threads of bolts. Bolts shall be fastened sequentially to make sure the level contact between flange and gasket.

To install a valve to the pipe, centration and parallelism are of vital importance. If the valve is not parallel, some parts of sealing face must be curved to realize sealing. Only the force exert on bolts will curve the piping or valve. Especially on larger sized pipings, such circumstances must be noted by installer and emergent actions shall be prepared.

Additionally, as described above, bolts shall be fastened by torque wrench. If the torques changes when fastening, bolts must be deformed, it must be abandoned.

6.3 Installation for Welding-end Valves

Piping and valve body are consecutive on structural and metallography. When installing pipe-valve-pipe, care should be taken to avoid gaps or weak connections. So for the welding valves, the welding gap size shall be larger than piping sectional size.

Butt Welding gap shall be fully welded and the depth of welding shall be at least the same



to valve wall thickness. If high strength alloy piping is to weld with low strength valve material, welding divided edge shall be machined to tapered shape to amend bigger wall thickness of valve end, or valve shall be equipped with high strength material support.

Welding valve to the pipe, following instructions shall be read:

- a) Check material of valve and piping to confirm they are of standard.
- b) Check the surface, size and cleanness of welding. Get rid of factors that will hamper installation and welding.
- c) If sealing ring is to be located, check the consistency and cleanness of material.
- d) Determine welding parameter by approved welding procedure, including pre-heating and treatment.
- e) Check if valve and piping are centralized, if not, make proper adjustment, then spot weld firmly.
- f) Finish the welding as per approved welding procedure.
- g) Check and clean the welding gap, if necessary, repair as per approved welding procedure.

6.4 Threaded Valve Installation

Sealing capacity of thread ended valves are decided by coordination of male threads and female threads. In order to get the most reliable sealing condition, following instructions shall be noted:

- a) Check the cleanness and shape of pipings. Notice whether the thread is damaged or serrated, whether there are scraps and sands.
- b) Pay attention to the inside thread length and distance to partition, take good care of the length thread into the valve. Make sure thread length of the piping does not exceed the length of valve.
- c) Correctly use the coordinated threads when installing. Taper threads shall be coordinated with thread when starting to fasten. Wrench can not be forced until threads are perfectly



matched.

d) Twist sealing tapes on the surface of piping thread or glue (except for thread sealing valves). Prevent tapes or glues from entering the pipe.

e) Fasten the assembly gap. Wrench of valve shall be at the valve bottom, pipes are fasten by threads. The torques formed by conic has no definite boundary, so over-wrench will damage valve or pipe.

f) Repeat the following steps and fasten the valve on the other side of valve.

7. Test and Adjustment

After strict check and installation, valve shall be in a good state and ready to be operated. However, valve and the whole service system are under last phase of danger. Only testing can testify its performance.

At this time, stem sealing and packing shall be checked. Stuffing cover shall be at the initial position.

8. Operation and Maintenance

Valve is the special product that has regular movement and frictions. In order to get satisfactory performance, some parts of machine parts shall be carefully protected.

In the proper state of pressure, medium, temperature, consecutive life-extension of a valve will be no less than 3 years.

8.1 Manual Valve Operation

Most valves are operated by hand wheel, wrench and handles. Pay attention to the operation speed should neither be too fast nor too slow, and exert force at proper position. End position is vital important to valve performance.

Operating a manual valve, clockwise direction is Close, while anti-clockwise direction is Open.

The valve should be in the fully open/fully closed position and cannot be used as a



regulating valve.

8.2 Actuated Valve Operation

Functionally, the sealing ability is closely related to the valve, while the actuation method has little to do with the valve. The program is programmed inside the monitor and controller. The actuator must be adjusted to correctly open, close or move the sealing component to achieve the desired purpose. For valves with strict position requirements, external limit devices must also be installed.

8.3 Maintenance

Valve has the complex structure for a pressure vessel and operational machine, when maintaining the valve, occasional open/close shall be put into consideration. At the same time, static pressure state of valve shall also be considered.

When keeping the valve to a certain position, operational capacity of valve may be reduced. This is caused by accumulation of corrosive substances on moving parts. Under some circumstances, valve shall be circulated open/close periodically.

The intactness of pressure boundary requires the intactness of pressure-bearing parts, pressure-bearing shall be checked regularly.

Stem packing leakage is usually caused by packing friction and usually be repaired by fastening the stuffing cover. Over fastening the stuffing cover may increase the friction, and thus hardening operation and speeding up abrasion of packing. Severe working conditions increase the difficulty and are beyond the scope of repair in this manual, so if possible, telling us the working conditions before manufacturing will achieve better results.

Insulator of low temperature valve shall be checked and maintained periodically to prevent mal-function.

9. Possible Failures and Method to Repair



Possible Failures	Reasons	Methods to Repair
Leakage between wedge and seat	<ol style="list-style-type: none"> 1. Dregs adhered on sealing face 2. Abrasion or flushing of sealing face 3. Over torque operated to deform the wedge 	<ol style="list-style-type: none"> 1. Clean dregs 2. Rubbing sealing face, overlay and re-machine to sealing standard 3. Change the wedge
Leakage between body and bonnet	<ol style="list-style-type: none"> 1. Uneven forces of bolts 2. Damage of flange Sealing face 3. Gasket damage or failure 	<ol style="list-style-type: none"> 1. Evenly fasten bolts 2. Repair 3. Change Gasket
Leakage of stem Packing	<ol style="list-style-type: none"> 1. Stem packing is not fastened 2. Packing Consumption 3. Contact surface between stem and packing is damaged 	<ol style="list-style-type: none"> 1. Evenly fasten bolts of stuffing cover 2. Add proper packing 3. Repair stem surface or change the stem
Stem movement agility	<ol style="list-style-type: none"> 1. Stuffing box over-tight 2. Stuffing box deflection 3. Dregs on moving position 4. Thread damage on stem or wheel nut 5. Stem curve 	<ol style="list-style-type: none"> 1. Loosen bolts of Stuffing box 2. Proofread Stuffing box 3. Clean dregs, lubricate 4. Repair thread or change stem or wheel-nut 5. Proofread stem